

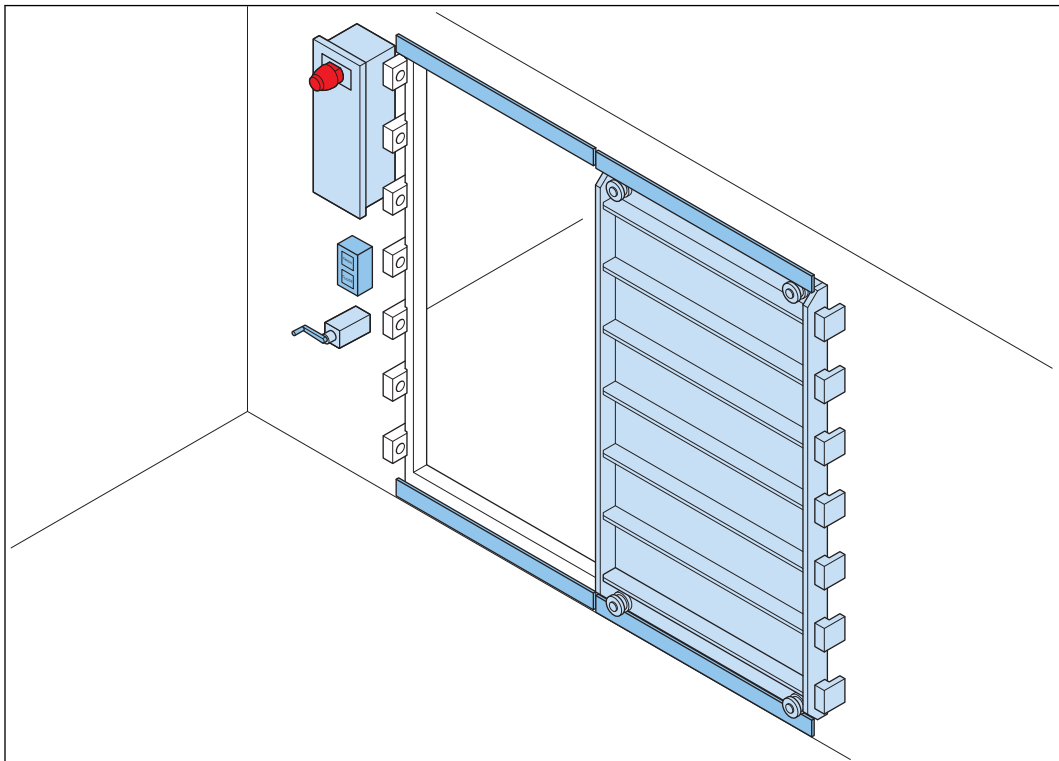

Installation, Operation & Maintenance Manual

Water Tight Sliding Door



Type Condor

Version: 1.0
Date: July 4, 2016

Contact information

WINEL BV

Dr. A. F. Philipsweg 55, 9403 AD Assen

P.O. box 70, 9400 AB Assen

The Netherlands

Tel. +31 (0)592 366060

Fax. +31 (0)592 340833

E-mail: info@winel.nl

www.winel.nl

Contents

1	About this manual.....	5
1.1	Contents of this manual.....	5
1.2	Intended audience.....	5
1.3	Revision history.....	5
1.4	Copyright and disclaimer.....	5
1.5	Symbols used in this manual.....	5
1.6	List of abbreviations.....	6
2	Safety and warranty.....	7
2.1	General safety instructions.....	7
2.2	Specific safety instructions.....	7
	2.2.1 Safety instructions for the electric system.....	7
2.3	Use of spare parts.....	8
3	Introduction to the product.....	9
3.1	Intended use.....	9
3.2	Product identification.....	9
3.3	Product description.....	10
	3.3.1 Overview of the WTSD.....	10
	3.3.2 Overview of the Push button controls.....	11
	3.3.3 Overview of the Handgenerator.....	11
	3.3.4 Overview of the Emergency station.....	11
	3.3.5 Working principle.....	12
4	Installation.....	13
4.1	Delivery, insurance and acceptance.....	13
	4.1.1 Delivery.....	13
	4.1.2 Insurance.....	13
	4.1.3 Acceptance.....	13
4.2	Recommendations for handling and unpacking.....	13
4.3	Storage.....	14
	4.3.1 Warehouse storage.....	14
	4.3.2 On-board storage.....	14
4.4	Welding.....	14
	4.4.1 General welding recommendations.....	14
	4.4.2 Welding recommendations for the door frame.....	15
4.5	Electrics.....	15
	4.5.1 General remarks about the electrical connection.....	15
	4.5.2 Connect the control box and the indication panel.....	15
	4.5.3 Connection of the proximity switches.....	15
	4.5.4 Connection of the local sounder and flashlight.....	15
	4.5.5 Connect the push buttons.....	15
	4.5.6 Connection of the 24 Vdc handgenerator.....	16
	4.5.7 Connection of the Emergency station (optional).....	16
5	Commissioning.....	17
5.1	General commissioning recommendations.....	17

- 5.2 Visual inspection..... 17
- 5.3 Checks before operation..... 17
 - 5.3.1 Checks of the door and the frame..... 17
 - 5.3.2 Check of the arrangement of the E-motor..... 17
 - 5.3.3 Check of the arrangement of the driving chain..... 17
- 5.4 Operational test..... 18
 - 5.4.1 Normal operation..... 18
 - 5.4.2 Emergency operation..... 18

- 6 Operation..... 20**
 - 6.1 Normal operation..... 20
 - 6.1.1 Pass a door..... 20
 - 6.1.2 Remote operation from the wheelhouse panel..... 21
 - 6.2 Emergency operation..... 22
 - 6.2.1 Local operation..... 22
 - 6.2.2 Use the emergency station to close the door..... 22

- 7 Maintenance..... 24**
 - 7.1 Maintenance schedule..... 24
 - 7.2 Maintenance tasks..... 24
 - 7.2.1 General recommendations for maintenance..... 24
 - 7.2.2 Apply new paint..... 25
 - 7.2.3 Clean and grease the door seal and the seal contact face of the door..... 25

1 About this manual

1.1 Contents of this manual

This manual contains information about the installation, operation and maintenance of the water tight sliding door (in this manual often referred to as "product").

1.2 Intended audience

This manual is intended for:

- Personnel that installs the product.
- Personnel that operates the product.
- Personnel that does maintenance and repairs on the product.

1.3 Revision history

Version	Release date	Changes
1.0	July 4, 2016	First release

1.4 Copyright and disclaimer

© 2016 WINEL BV. All rights reserved.

No part of this document may be reproduced, distributed or transmitted in any form or by any means, electronically or mechanically, including photocopying and recording for any purpose, without the express written authorisation by WINEL BV.

WINEL BV continuously improves its products, therefor the designs and specifications in this manual are subject to change without prior notice.

1.5 Symbols used in this manual



Danger:

This indicates a situation with a high level of risk which, if not avoided, can cause death or serious injury.



Warning:

This indicates a situation with a medium level of risk which, if not avoided, can cause serious injury or serious damage to the product.



Caution:

This indicates a situation with a low level of risk which, if not avoided, can cause moderate or minor injury or damage or the product.



Note:

This provides useful background information that is not hazard related.

1.6 List of abbreviations

Abbreviation	Description
GA drawing	General Arrangement drawing
WHP	Wheelhouse Panel
WTSD	Water Tight Sliding Door

2 Safety and warranty

2.1 General safety instructions



Danger:

The door can close automatically. If needed, ask for help to keep the door open!

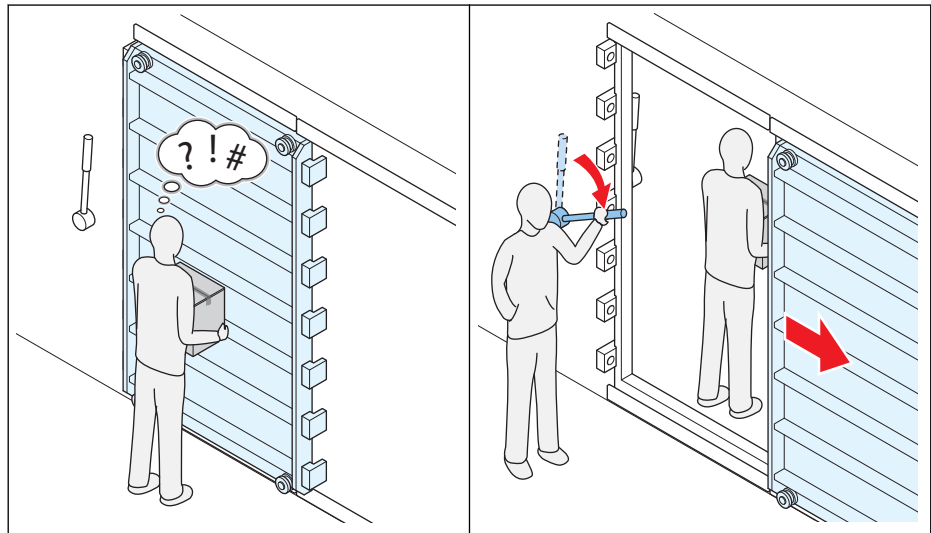

- Always read the instructions of this product before you operate the product. NOT following the instructions can put persons and the environment in danger.
- The door(s) must be operated by qualified personnel.
- Follow the maintenance instructions given by WINEL BV. This is in the interest of safety and reliability of the vessel and of its crew and passengers.
- No welding or modification to the product is allowed without prior written approval and permission of WINEL BV and the certifying authorities.
- Disconnect all electrical wiring before welding activities near the product. The welding current can cause damage to the electrics and electronics of the product.

2.2 Specific safety instructions

2.2.1 Safety instructions for the electric system



Danger:

Some parts of the installation use high voltages.

Only qualified personnel is allowed to perform installation and maintenance procedures on the system.

Make sure that you switch off the power to the product before you connect or disconnect any cables.



Danger:

If the system is controlled from a remotely located panel, or central station, always lock-out the remote control by switching-off the remote control power supply during maintenance. This prevents the door from closing unexpected.

2.3 Use of spare parts

- Only use original WINEL BV spare parts or spare parts that are recommended by WINEL BV.

The use of other parts can result in unsafe operations and severe damage to the equipment, to personnel and to the environment.

- All damage resulting from the use of non-original spare parts is beyond the responsibility of WINEL BV.
- WINEL BV only accepts warranty claims if the maintenance instructions are carefully followed and if original WINEL BV spare parts have been used.

In case of neglected maintenance procedures and mounting non-WINEL BV parts, WINEL BV will not accept any responsibility.

3 Introduction to the product

3.1 Intended use

The WINELOGO BV Water Tight Sliding Doors are designed to (when open) allow the passage of people and goods through water tight bulkheads and (when closed) to maintain the water tight integrity of the bulkhead in which it is located. Each Water Tight Sliding Door is supplied as a completely finished and tested product ready to be installed in the bulkhead of a vessel.

3.2 Product identification

		Winel B.V. Dr. A.F. Philipsweg 55 P.O. Box 70, 9400 AB ASSEN The Netherlands		Tel. : 31 (0)592-36 60 60 Fax. : 31 (0)592-31 23 92 E-Mail : info@winel.nl.
		A	Order No. :	Type :
B	Year :	Pressure Head :	E	
C	Class :	Item No. :	F	

- A. The WINELOGO BV order number
- B. The year of manufacturing
- C. The classification society that classifies the vessel
- D. The door type
- E. The maximum amount of water pressure for which product is designed
- F. The item number as assigned by WINELOGO BV

3.3 Product description

3.3.1 Overview of the WTSD

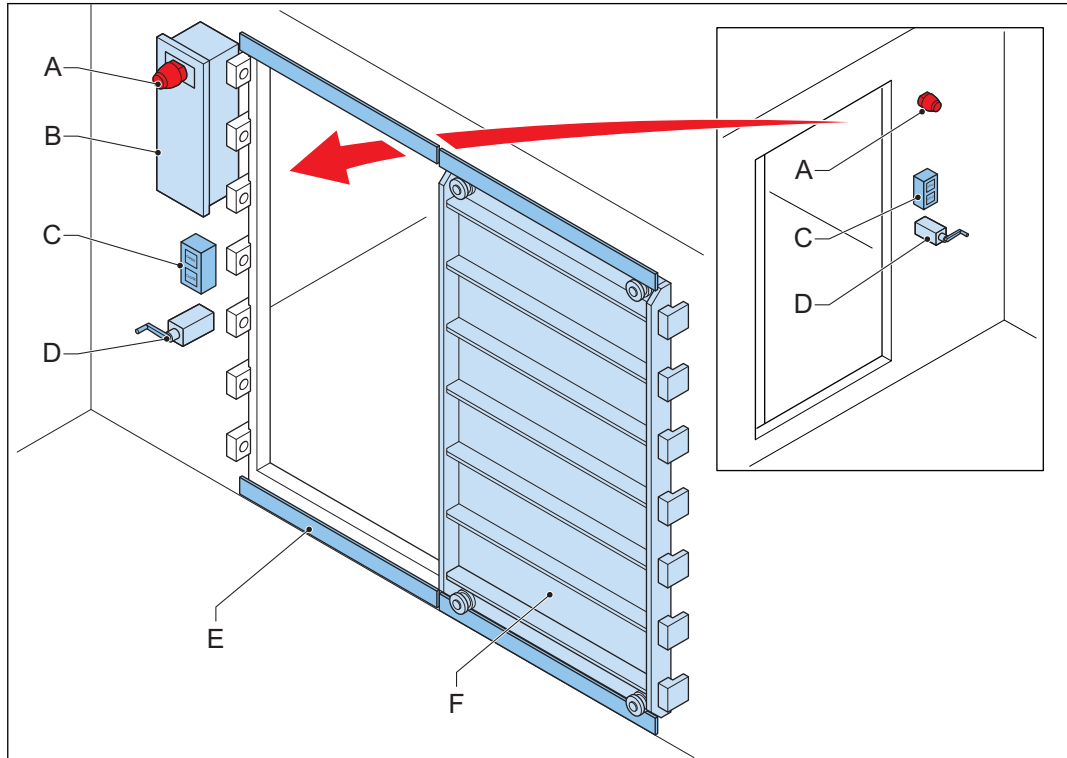

- A. Sounder/flashlight (one on each side of the bulkhead)
- B. Electric/mechanical control box
- C. Push button control box (one on each side of the bulkhead)
- D. Emergency handgenerator (one on each side of the bulkhead)
- E. Sliding rail
- F. Door plate

For specific details about the door installed on the vessel, refer to the GA drawings and the documentation enclosed.

3.3.2 Overview of the Push button controls

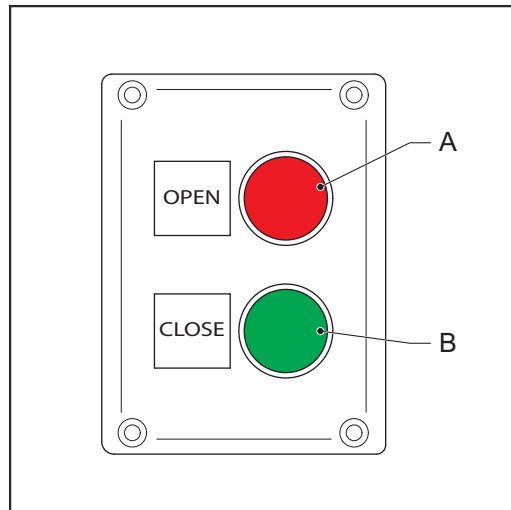

- A. Button **OPEN**
- B. Button **CLOSE**

3.3.3 Overview of the Handgenerator

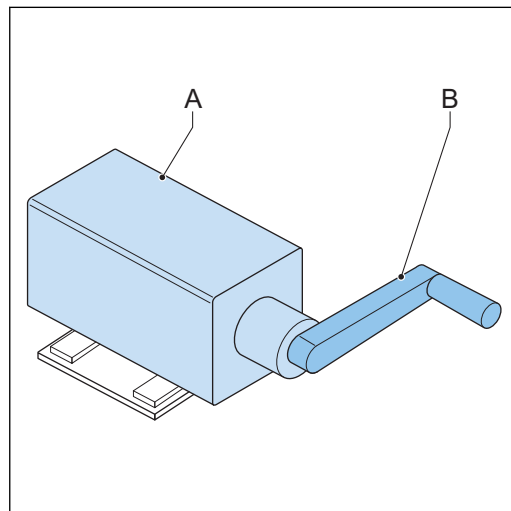

- A. Generator house (24 Vdc)
- B. Handle

3.3.4 Overview of the Emergency station

The emergency station is optional. Refer to the documentation enclosed to see if an emergency station is installed. The exact layout of an emergency station can differ per location and per vessel.

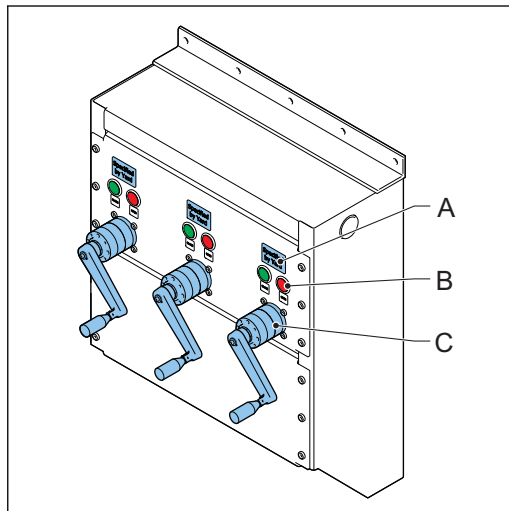

A. Name plate (door number/location)

B. Indicator lights:

- Indicator **DOOR OPENED**
- Indicator **DOOR CLOSED**

C. Handgenerator

3.3.5 Working principle

The electric door is operated by an electric system and controlled by a PLC. The user can open and close the door with push buttons that are located near the door at both sides of the bulkhead. The push buttons operate an electric motor which drives a gearbox and chain which opens and closes the door.

Optionally:

- The door can be closed from an emergency station above the freeboard deck.
- All doors can be closed from a wheelhouse panel (central close).

4 Installation

4.1 Delivery, insurance and acceptance

4.1.1 Delivery

Depending on the scope of supply, the parts are packed and transported in the following ways:

Door assembly

The doorframe including the door is placed on a pallet and strapped with bands. Depending on the scope of supply, the electric components and the hydraulic components are pre-mounted on the doorframe, or they are delivered separately.

Electric components

When the components are not pre-mounted on the doorframe, they are packed and sealed on pallet and/or in a labelled cardboard box. Inside this box, the components that belong to sub-systems (e.g. a wheelhouse panel) are packed per sub-system.

The contents of the boxes is shown on labels and on the packing list.

4.1.2 Insurance

The responsibilities of transport and insurance are stated in the sales order confirmation and in the general conditions of sale of WINEL BV.

4.1.3 Acceptance

During acceptance of the delivery, WINEL BV recommends to proceed as follows:

Procedure

1. WINEL BV recommends to have an authorized official of the transportation company present during this procedure.
2. Check if the packing and all the pallets and/or boxes are undamaged and if all parts are present.
 - a) Compare the labels with the WINEL BV packing list and the order confirmation.
 - b) If there is damage or if parts are missing, immediately report this to the sales department of WINEL BV.

4.2 Recommendations for handling and unpacking

General

- Use a fork lift or a hoist to transport the pallets or the boxes as close to the installation site as possible.
- Do not use hooks or other tools that may penetrate the packing and cause damage to the packed items.
- Only use lifting equipment with adequate capacity for the load.

For the weights and dimensions of the delivery, refer to the GA drawings enclosed.

- Only unpack the parts in the cardboard boxes just before you install them. This prevents parts from being lost.

- Use a sharp knife to open the cardboard boxes but take care not to cause damage to the parts inside the boxes.

Door assembly (door frame with door and components)



Danger:

The door assembly is heavy.

Use correct and certified lifting materials.

Only authorized personnel is allowed to operate the lifting equipment.

Follow the appropriate safety procedures.

- Remove the band that holds the door assembly to the pallet.
- Make sure that the door itself is secured in the closed position. This prevents that the door moves during the lifting operation.
- Use the lifting eye on top of the door frame to attach the door to the lifting equipment.
- Use at least two steadying lines to guide the door assembly during the lifting operation.

4.3 Storage

4.3.1 Warehouse storage

- Store the parts in a safe, dry and dust free environment.
This prevents unnecessary damage and wear of the parts.
- If the parts were unpacked from their transport packing, repack the parts using appropriate packing materials.
- Use the original WINEL BV WTSD pallet to store the door assembly.
- Do NOT stack pallets containing WTSDs on top of each other.

4.3.2 On-board storage

- Store the parts as close as possible to the future position.
- Make sure to place the door assembly at the correct side of the bulkhead.
- Make sure to protect the parts from damage caused by work in the vicinity of the parts.
- Re-pack or cover the door assembly and the other parts in order to prevent damage by grinding or welding nearby.

4.4 Welding

4.4.1 General welding recommendations



Danger:

Welding the door frame into or against the bulkhead must be done by certified and qualified welder and according to requirements of the shipyard.

WINEL BV cannot be held responsible if the welding recommendation and the advised welding procedures were not followed.

- WINEL BV can only make welding recommendations with respect to the WTSD, and not with respect to the construction of the vessel which the WTSD is placed into.

4.4.2 Welding recommendations for the door frame



Caution:

KEEP THE DOOR CLOSED DURING THE ENTIRE WELDING PROCEDURE.

When the door is not closed during welding, the watertightness of the door cannot be guaranteed.

- For welding details, refer to the Welding and parts drawings enclosed.
- Make sure that the heat-dissipation into the door is as little as possible.
- Welding must be done carefully to prevent thermal stresses in the door.

4.5 Electrics

4.5.1 General remarks about the electrical connection



Caution:

Always switch off all electrical power before you do any installation, removal or maintenance work.

- Refer to the overview diagram enclosed for cable information (wires/diameters).

4.5.2 Connect the control box and the indication panel

Procedure

Connect the external electrical connections to the terminal strip inside the control box or inside the indication panel.

Refer to the connection diagrams enclosed.

4.5.3 Connection of the proximity switches

The proximity switches on electric and electro-hydraulic WTSD are pre-mounted and connected to the terminal strip.

No additional connection work is required.

4.5.4 Connection of the local sounder and flashlight

The local sounder/flashlight on electric and electro-hydraulic WTSDs are pre-mounted and connected to the terminal strip.

No additional connection work is required.

4.5.5 Connect the push buttons

The push buttons are installed in a push button boxes on both sides of the bulkhead.

These boxes:

- Must be mounted on a mounting plate that must be welded on the bulkhead at a height of at least 1.6 m from the floor
- Must both be reachable at the same time by one person when the door is open.

Procedure

1. Mount the push button box to the mounting plate.
2. Connect the push buttons to the terminal strip inside the control box.

Refer to the connection diagrams enclosed.

4.5.6 Connection of the 24 Vdc handgenerator

Procedure

1. Mount a handgenerator at both sides of the bulkhead. Use the mounting brackets.
2. Connect the handgenerator to the terminal strip inside the control box.

Refer to the connection diagrams enclosed.

4.5.7 Connection of the Emergency station (optional)

The emergency station is optional. Refer to the documentation enclosed to see if an emergency station is installed

Procedure

1. Mount the emergency station at the desired location above the freeboard deck. Use the mounting bracket that is placed inside the emergency station.
2. Connect the emergency station to the terminal strip inside the control box.

Refer to the connection diagrams enclosed.

5 Commissioning

5.1 General commissioning recommendations

When the installation of the WTSD is completed, the WTSD must be commissioned. This involves the following procedures that must get full attention:

- Visual inspection;
- Checks before operation;
- Operational tests.

5.2 Visual inspection

Procedure

1. Examine the WTSD for damage dirt and leaks of lubrication fluid from the gear box.
2. If necessary, replace damaged parts.
3. If necessary, repair any leaks or damage and remove dirt.

5.3 Checks before operation

5.3.1 Checks of the door and the frame

Procedure

1. Examine the door seal and the seal face of the door for damage and dirt.
2. If necessary, repair any damage and clean the items.
3. If the door seal is damaged, replace the door seal.
4. Lubricate the door seal with acid free Vaseline.

5.3.2 Check of the arrangement of the E-motor

Procedure

1. Check the alignment of the driving rod and the gears.
2. Check if the moving parts are free from obstacles.

5.3.3 Check of the arrangement of the driving chain

Procedure

1. Check the alignment of the driving wheels and the driving chain.
2. Check if the moving parts are free from obstacles.
3. Check the tension of the driving chain.

5.4 Operational test

5.4.1 Normal operation

Local manual operation



Caution:

Make sure that there are no obstacles that prevent the door from closing or opening.

Procedure

1. Switch on the main power.
This switch is located in the electric control box.
2. Check if all the switches and the circuit breakers are set correctly.
Refer to the connection diagrams enclosed.
3. Operate the local push buttons of the door, and check if:
 - a) The door opens and closes, depending on the selected button.
 - b) The local sounder/flashlight makes a sound and flashes when the door opens or closes.
 - c) The opening time and the closing time of the door is between 20 and 40 seconds (for doors with a clear opening width of max. 1200 mm)
 - d) (optional) The indicator lights of the emergency station or other remote control positions change color depending on the door position:
 - Door closed: green light
 - Door open: red light
 - Door in intermediate position (between open and closed): red light flashes

Remote operation from the wheelhouse panel

The wheelhouse panel is optional. Refer to the documentation enclosed to see if a wheelhouse panel is installed.



Caution:

Make sure that there are no obstacles that prevent the door from closing.

Procedure

1. On the wheelhouse panel, set the switch **MASTERMODE** to **CENTRAL CLOSE**, and check if:
 - The indicator **CENTRAL CLOSE** lights up.
 - Within 5-10 second all open doors start closing.
 - The red indicator light of each door flashes until the door is closed.
 - When the door is closed, the green indicator lights up.
2. On the wheelhouse panel, set the switch **MASTERMODE** to **LOCAL CONTROL**.

5.4.2 Emergency operation

Local manual operation

Procedure

1. Switch off the main power.

This switch is located in the electric control box.

2. Operate the handgenerator, and check if:
 - a) The door opens when the handle of the handgenerator is rotated in the open-direction.
 - b) The door closes when the handle of the handgenerator is rotated in the close-direction.
 - c) The door closes within 90 seconds (for doors with a clear opening width of max. 1200 mm)
 - d) (optional) The indicator lights of the emergency station or other remote control positions change color depending on the door position:
 - Door closed: green light
 - Door open: red light
 - Door in intermediate position (between open and closed): red light flashes

Emergency station

The emergency station is optional. Refer to the documentation enclosed to see if an emergency station is installed.

Procedure

1. Go to the emergency station above the freeboard deck.
2. Operate the handpump or the generator, and check if:
 - a) The door closes within 90 seconds (for doors with a clear opening width of max. 1200 mm)
 - b) The indicator lights of the emergency station change color depended on the door position.
 - Door closed: green light
 - Door open: red light
 - Door in intermediate position (between open and closed): red light flashes
 - c) The local sounder/flashlight makes a sound and flashes when the door closes (only when electrical power is available).

6 Operation

6.1 Normal operation

6.1.1 Pass a door

Open the door

Procedure

1. Push the button **Open** until the door is fully opened.
The door moves and the sounder and flashlight are active until the door is fully opened.
2. If you release the button, the door stops.
If the door is controlled from the wheelhouse, the door closes after 5-10 seconds. The sounder and the flashlight will stay active until the door is fully closed.

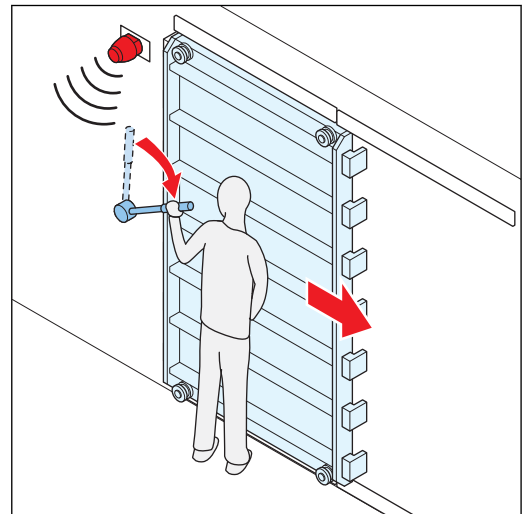

Step through the door opening

Procedure

1. Use both hands to push the buttons **Open** in order to keep the door open.
2. Step through the door opening.

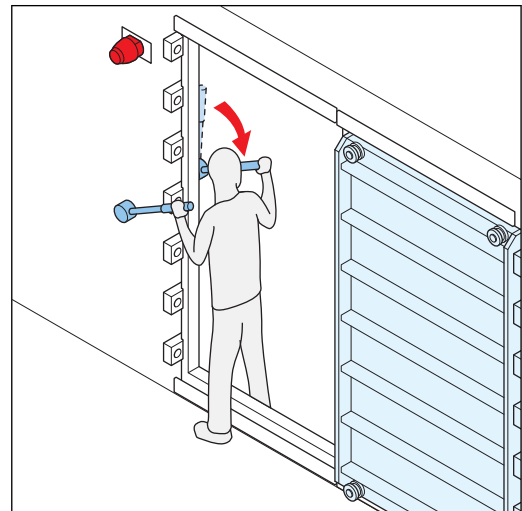

Close the door

Procedure

1. Stand clear of the door.
2. Push the button **Close** until the door is fully closed.
The door moves and the sounder and flashlight are active until the door is fully closed.

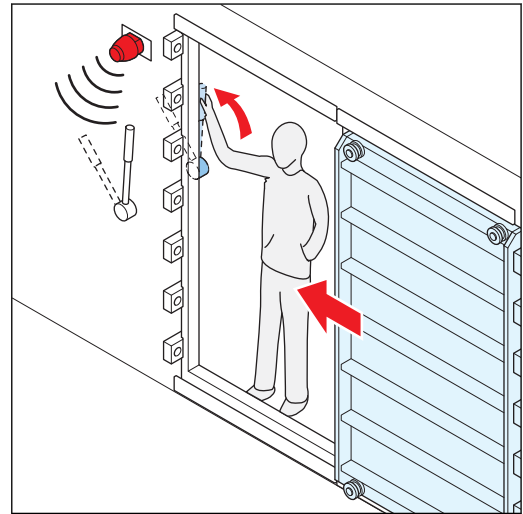

6.1.2 Remote operation from the wheelhouse panel

The wheelhouse panel is optional. Refer to the documentation enclosed to see if a wheelhouse panel is installed.

Set all doors to central control



Caution:

Make sure that there are no obstacles that prevent the door from closing.

Procedure

1. On the wheelhouse panel, set the switch **MASTERMODE** to **CENTRAL CLOSE**.
 - The indicator **CENTRAL CLOSE** lights up.
 - Within 5-10 second all open doors start closing.
 - The red indicator light of each door flashes until the door is closed.
 - When the door is closed, the green indicator light lights up.
2. Check the indicator lights to see if all doors are closed.

All doors are now closed, and they will remain closed. When a person wants to pass a door, he/she has to use the local controls. As soon as the local controls are released, the door automatically closes again.

Open all doors

Opening the doors is NOT possible from the wheelhouse panel.

Set all doors to local control

Procedure

1. On the wheelhouse panel, set the switch **MASTERMODE** to **LOCAL CONTROL**.
2. Check if the indicator **CENTRAL CLOSE** is off.
All doors can now be fully controlled locally. If a person at the door releases the local controls, the door will stay in its current position.

6.2 Emergency operation

6.2.1 Local operation

General

These procedures must be followed when the door cannot be operated in the normal way (e.g. during a power failure).

Open the door

Procedure

1. Go to the handgenerator (A).
2. Turn the handle of the handgenerator into the opening direction until the door is fully opened.

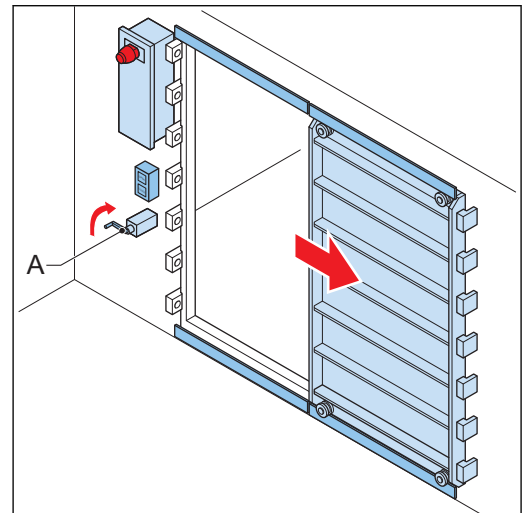

Close the door

Procedure

1. Go to the handgenerator (A).
2. Turn the handle of the handgenerator into the closing direction until the door is fully closed.

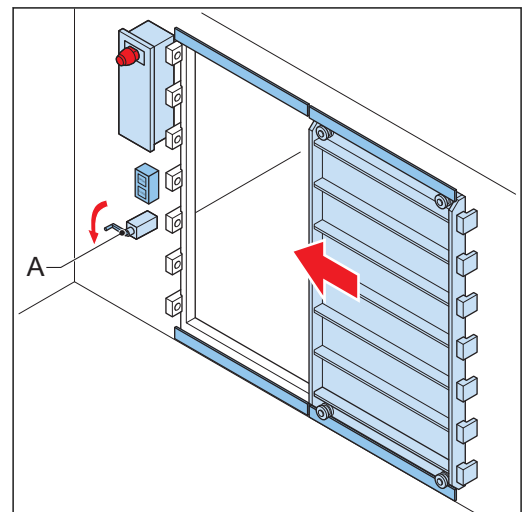

6.2.2 Use the emergency station to close the door

The optional emergency station can only be used to close the door.

This procedure must be followed when the door cannot be closed in a normal way: locally via the handgenerator or remotely via the wheelhouse panel.

Procedure

1. Make sure to select the door that needs to be closed.
See the nameplate (A).
2. Turn the handle (C) clockwise until the indicator **Closed** lights up.

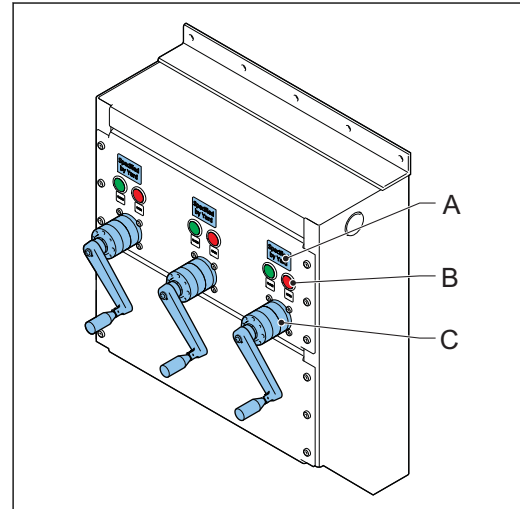

7 Maintenance

7.1 Maintenance schedule

Inspection intervals

Daily and (on vessels) before departure:

- Check the free passage of the door and remove obstacles that prevent the door from closing.
- Check if the drive chain is not blocked.
- Check for dirt or damage.
- Check for unusual noises from pumps, motors, couplings, mountings etc.
- Check for proper functioning of instruments.

Weekly:

- Check the door seal and the sealing surface of the door for damage.
- Check the wedges and blocking cones.
Lubricate them if necessary.
- Clean the rails and the sill (if applicable).
- Check the tension on the driving chain

Monthly:

- Check the operation of the complete system, including the visible and audible alarms.

Every two months:

- Check the settings and signalling devices.

Service intervals

gear box:

- Refer to the documentation enclosed.

Drive chain:

- In normal conditions the chain does not need any regular maintenance.
- The chain does not need any lubrication.
To reduce running noise, "WINEL BV chain grease" can be used.
- After long and intensive use, the chain has to be retightened.

7.2 Maintenance tasks

7.2.1 General recommendations for maintenance

Regular inspections and maintenance helps to keep the product in optimal condition. Be constantly alert for:

- External leaks
- Dirt
- Damage
- Unusual noises from pumps, motors, couplings, mountings etc.
- Proper operation of instruments

Grease and corrosion inhibitors

**Caution:**

Do NOT lubricate the bearing of the wheels. The wheels are equipped with self-lubricating bushes. If lubrication is nevertheless necessary, use PH neutral grease.

**Note:**

Some types of corrosion inhibitors can cause damage to seals.

7.2.2

Apply new paint

All corrodible parts of the WTSD are covered by a protective paint. Only repaint the part if necessary. Use the original colors.

**Note:**

Paint at the wrong location can cause system failure or it can obstruct an easy removal of system parts.

If you apply new paint:

Procedure

1. Do not paint non-painted parts such as: proximity switches, cylinder rods, control boxes and indication boxes.
2. Cover parts that do not need new paint.

7.2.3

Clean and grease the door seal and the seal contact face of the door

Procedure

1. Clean the door seal and the seal contact face of the door. Use a dry cloth.
2. Apply a little acid free Vaseline to the door seal.