

Outside View

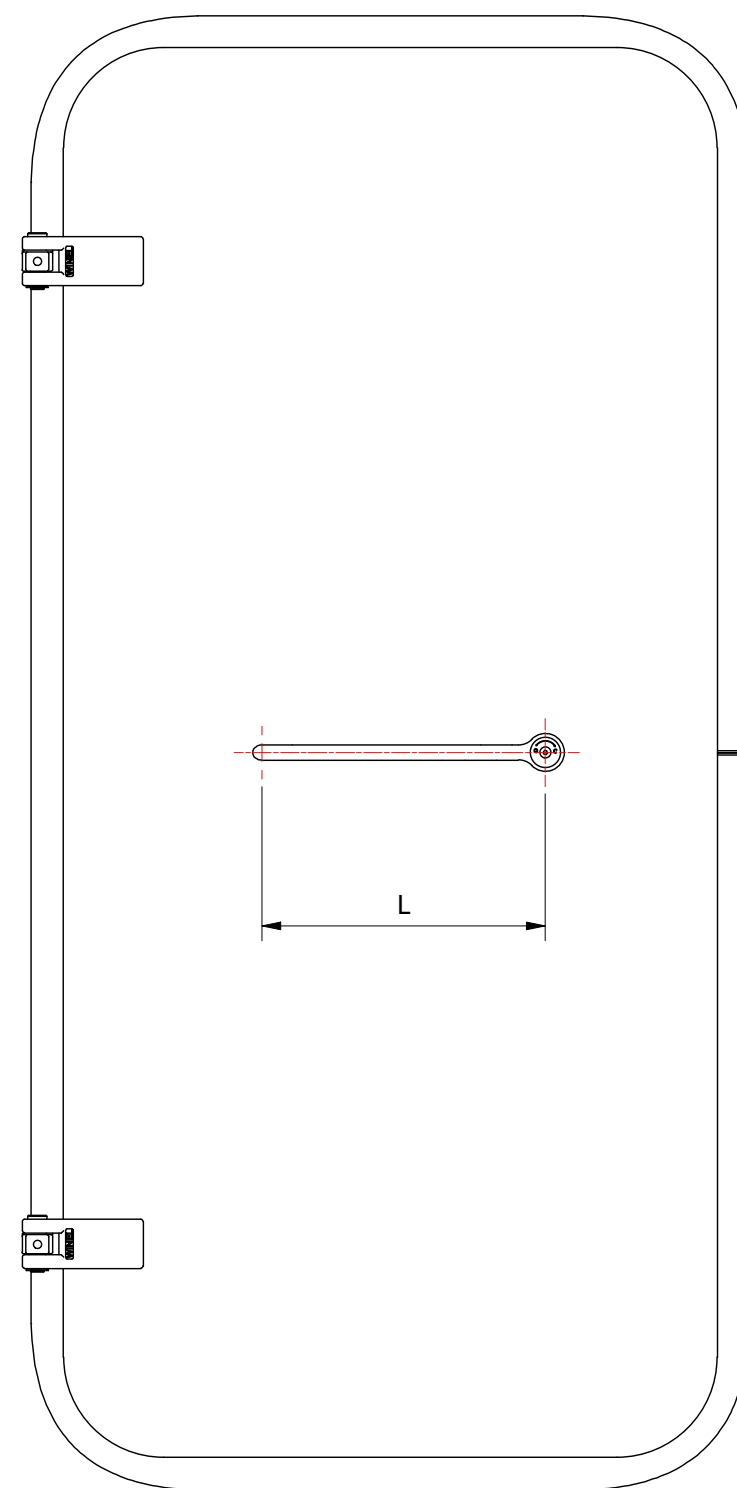

- Doorplate: Grade A ; 8 mm
- Coaming: 75x50x7 Steel
- Cleats: Cast stainless steel: 1.4408 / ATSM CF8M equivalent to 1.4404 / AISI 316
- Mechanism: Stainless Steel 1.4404 / AISI 316L
- Seal: Seal 42.5x20.4 EPDM
- Wedge: Brass
- Hinge: Stainless Steel with Orkot® bearing and Stainless Steel Axle

- Insulation : Rockwool Marineslab 55 or FireMaster Marine Plus Blanket :40mm / 70 kg m³

- Clear Opening: H x W
- Cut in plate: H + 75 x W + 75
- Outside dimensions: H + 150 x W + 150
- Handle length: L =375

	RM	22-5-2023	-
Revision Description	Name	Date	Rev
	Status:	WorkInProgress	
	Engineer:	RM	25-2-2022
American projection:	Description: WET Door - Fast Lane Line		
 <small> info@winel.nl www.winel.nl +31 (0)592 366 060 </small>	Reference: Winel Prodcut Catalog		
	Drawing number: 9541 . FLL	Rev.	Sheet 1 / 1
<small> Dr. A.F. Philipsweg 55 9403 AD Assen The Netherlands </small>			
<small>The drawing and design shown is our property and may not be used or disclosed for any third person without our specific written approval.</small>			