

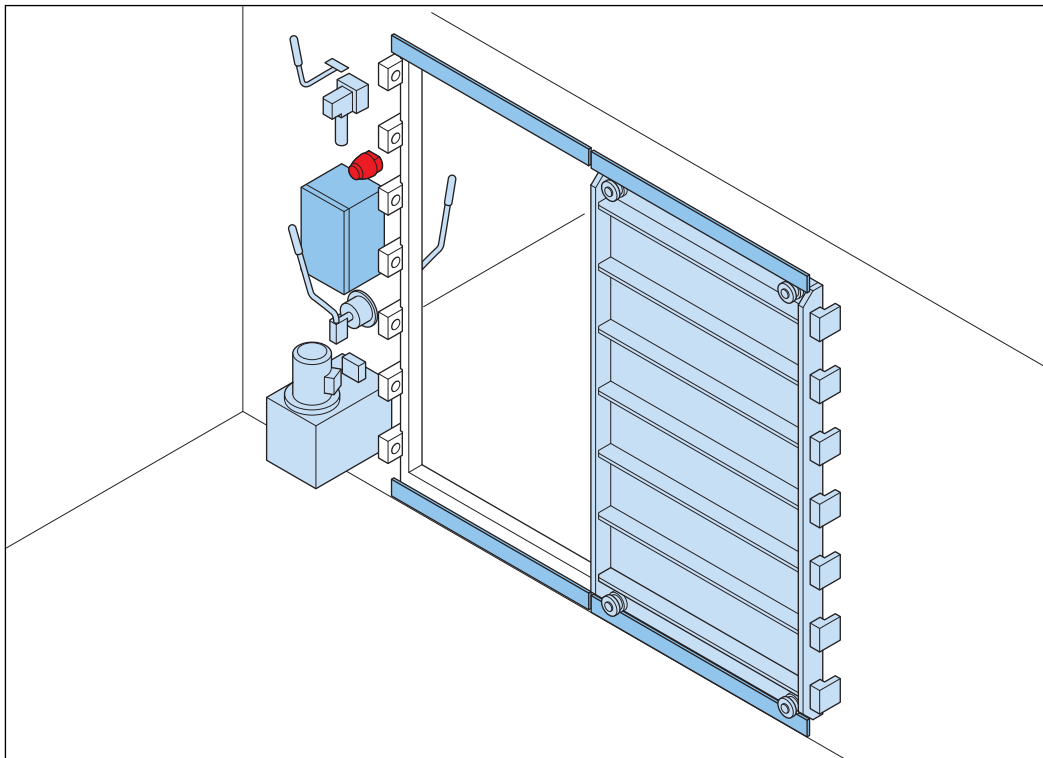

# Installation, Operation & Maintenance Manual

## Water Tight Sliding Door



### Type Eagle

Version: 2.0  
Date: July 4, 2016

## Contact information

### **WINEL BV**

Dr. A. F. Philipsweg 55, 9403 AD Assen

P.O. box 70, 9400 AB Assen

The Netherlands

Tel. +31 (0)592 366060

Fax. +31 (0)592 340833

E-mail: [info@winel.nl](mailto:info@winel.nl)

[www.winel.nl](http://www.winel.nl)

# Contents

<b>1</b>	<b>About this manual.....</b>	<b>5</b>
1.1	Contents of this manual.....	5
1.2	Intended audience.....	5
1.3	Revision history.....	5
1.4	Copyright and disclaimer.....	5
1.5	Symbols used in this manual.....	5
1.6	List of abbreviations.....	6
<b>2</b>	<b>Safety and warranty.....</b>	<b>7</b>
2.1	General safety instructions.....	7
2.2	Specific safety instructions.....	7
2.2.1	Safety instructions for the electric system.....	7
2.2.2	Safety instructions for the hydraulic system.....	8
2.3	Use of spare parts.....	8
<b>3</b>	<b>Introduction to the product.....</b>	<b>9</b>
3.1	Intended use.....	9
3.2	Product identification.....	9
3.3	Product description.....	10
3.3.1	Overview of the WTSD.....	10
3.3.2	Overview of the Push button controls.....	10
3.3.3	Overview of the Emergency station.....	11
3.3.4	Overview of the Indication box (emergency station).....	12
3.3.5	Overview of the Handpump (emergency station).....	12
3.3.6	Working principle.....	12
<b>4</b>	<b>Installation.....</b>	<b>14</b>
4.1	Delivery, insurance and acceptance.....	14
4.1.1	Delivery.....	14
4.1.2	Insurance.....	14
4.1.3	Acceptance.....	14
4.2	Recommendations for handling and unpacking.....	14
4.3	Storage.....	15
4.3.1	Warehouse storage.....	15
4.3.2	On-board storage.....	15
4.4	Welding.....	15
4.4.1	General welding recommendations.....	15
4.4.2	Welding recommendations for the door frame.....	16
4.4.3	Welding recommendations for the sliding rail extension.....	16
4.5	Hydraulics.....	16
4.5.1	Prepare the hydraulics for installation.....	16
4.5.2	Connect the hydraulics.....	16
4.5.3	Flush the piping of the hydraulics.....	17
4.5.4	Fill the hydraulic unit with hydraulic fluid.....	17
4.5.5	Air-bleed the hydraulics.....	18
4.6	Electrics.....	18
4.6.1	General remarks about the electrical connection.....	18
4.6.2	Connect the control box and the indication panel.....	18

- 4.6.3 Connection of the proximity switches..... 19
- 4.6.4 Connection of the local sounder and flashlight..... 19
- 4.6.5 Connect the push buttons..... 19
- 4.6.6 Connection of the indication box (emergency station)..... 19
  
- 5 Commissioning..... 20**
  - 5.1 General commissioning recommendations.....20
  - 5.2 Visual inspection..... 20
  - 5.3 Checks before operation.....20
    - 5.3.1 Checks of the door and the frame.....20
    - 5.3.2 Check of the valve settings..... 20
    - 5.3.3 Check of the hydraulic unit.....20
  - 5.4 Operational test.....21
    - 5.4.1 Normal operation.....21
    - 5.4.2 Emergency operation..... 21
  
- 6 Operation..... 23**
  - 6.1 Normal operation..... 23
    - 6.1.1 Pass a door..... 23
    - 6.1.2 Remote operation from the wheelhouse panel..... 24
  - 6.2 Emergency operation.....25
    - 6.2.1 Local operation.....25
    - 6.2.2 Use the emergency station to close the door.....25
  
- 7 Maintenance..... 27**
  - 7.1 Maintenance schedule..... 27
  - 7.2 Maintenance tasks..... 27
    - 7.2.1 General recommendations for maintenance..... 27
    - 7.2.2 Visually inspect hydraulic fluid..... 28
    - 7.2.3 Replace a filter for hydraulic fluid..... 29
    - 7.2.4 Apply new paint.....29
    - 7.2.5 Clean and grease the door seal and the seal contact face of the door.....29

# 1 About this manual

## 1.1 Contents of this manual

This manual contains information about the installation, operation and maintenance of the water tight sliding door (in this manual often referred to as "product").

## 1.2 Intended audience

This manual is intended for:

- Personnel that installs the product.
- Personnel that operates the product.
- Personnel that does maintenance and repairs on the product.

## 1.3 Revision history

Version	Release date	Changes
1.0	June 1, 2016	First release
2.0	July 4, 2016	Minor corrections

## 1.4 Copyright and disclaimer

© 2016 WINEL BV. All rights reserved.

No part of this document may be reproduced, distributed or transmitted in any form or by any means, electronically or mechanically, including photocopying and recording for any purpose, without the express written authorisation by WINEL BV.

WINEL BV continuously improves its products, therefor the designs and specifications in this manual are subject to change without prior notice.

## 1.5 Symbols used in this manual



### Danger:

This indicates a situation with a high level of risk which, if not avoided, can cause death or serious injury.



### Warning:

This indicates a situation with a medium level of risk which, if not avoided, can cause serious injury or serious damage to the product.



### Caution:

This indicates a situation with a low level of risk which, if not avoided, can cause moderate or minor injury or damage or the product.



### Note:

This provides useful background information that is not hazard related.

## 1.6 List of abbreviations

Abbreviation	Description
GA drawing	General Arrangement drawing
WHP	Wheelhouse Panel
WTSD	Water Tight Sliding Door

## 2 Safety and warranty

### 2.1 General safety instructions



**Danger:**

The door can close automatically. If needed, ask for help to keep the door open!

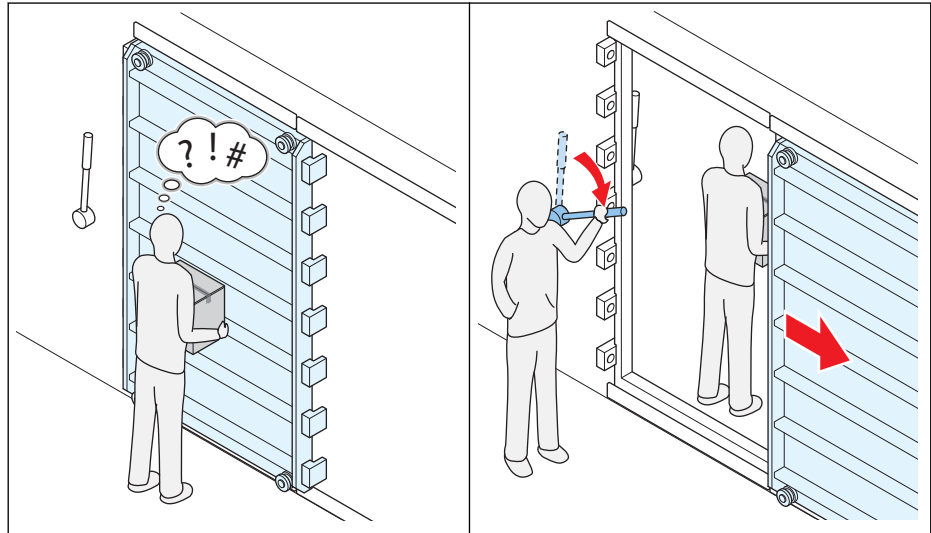

- Always read the instructions of this product before you operate the product. NOT following the instructions can put persons and the environment in danger.
- The door(s) must be operated by qualified personnel.
- Follow the maintenance instructions given by WINEL BV. This is in the interest of safety and reliability of the vessel and of its crew and passengers.
- No welding or modification to the product is allowed without prior written approval and permission of WINEL BV and the certifying authorities.
- Disconnect all electrical wiring before welding activities near the product. The welding current can cause damage to the electrics and electronics of the product.

### 2.2 Specific safety instructions

#### 2.2.1 Safety instructions for the electric system



**Danger:**

Some parts of the installation use high voltages.

Only qualified personnel is allowed to perform installation and maintenance procedures on the system.

Make sure that you switch off the power to the product before you connect or disconnect any cables.



**Danger:**

If the system is controlled from a remotely located panel, or central station, always lock-out the remote control by switching-off the remote control power supply during maintenance. This prevents the door from closing unexpected.

## 2.2.2 Safety instructions for the hydraulic system



**Danger:**

The hydraulic system uses pressurized hydraulic fluid.

Only qualified personnel is allowed to perform installation and maintenance procedures on the system.

Always switch off the pumps and (if an accumulator is installed) release the pressure from the accumulator before you start any work on the hydraulic system.

- If the system is under pressure, it is not allowed to loosen any pipe connectors, screw connectors or components.
- Never work with oily hands.

## 2.3 Use of spare parts

- Only use original WINEL BV spare parts or spare parts that are recommended by WINEL BV.

The use of other parts can result in unsafe operations and severe damage to the equipment, to personnel and to the environment.

- All damage resulting from the use of non-original spare parts is beyond the responsibility of WINEL BV.
- WINEL BV only accepts warranty claims if the maintenance instructions are carefully followed and if original WINEL BV spare parts have been used.

In case of neglected maintenance procedures and mounting non-WINEL BV parts, WINEL BV will not accept any responsibility.



### 3 Introduction to the product

#### 3.1 Intended use

The WINELOGO BV Water Tight Sliding Doors are designed to (when open) allow the passage of people and goods through water tight bulkheads and (when closed) to maintain the water tight integrity of the bulkhead in which it is located. Each Water Tight Sliding Door is supplied as a completely finished and tested product ready to be installed in the bulkhead of a vessel.

#### 3.2 Product identification

		Wine B.V. Dr. A.F. Philipsweg 55 P.O. Box 70, 9400 AB ASSEN The Netherlands		Tel. : 31 (0)592-36 60 60 Fax. : 31 (0)592-31 23 92 E-Mail : info@wine.nl.	
		A	Order No. :	Type :	D
B	Year :	Pressure Head :	E		
C	Class :	Item No. :	F		

- A. The WINELOGO BV order number
- B. The year of manufacturing
- C. The classification society that classifies the vessel
- D. The door type
- E. The maximum amount of water pressure for which product is designed
- F. The item number as assigned by WINELOGO BV

### 3.3 Product description

#### 3.3.1 Overview of the WTSD

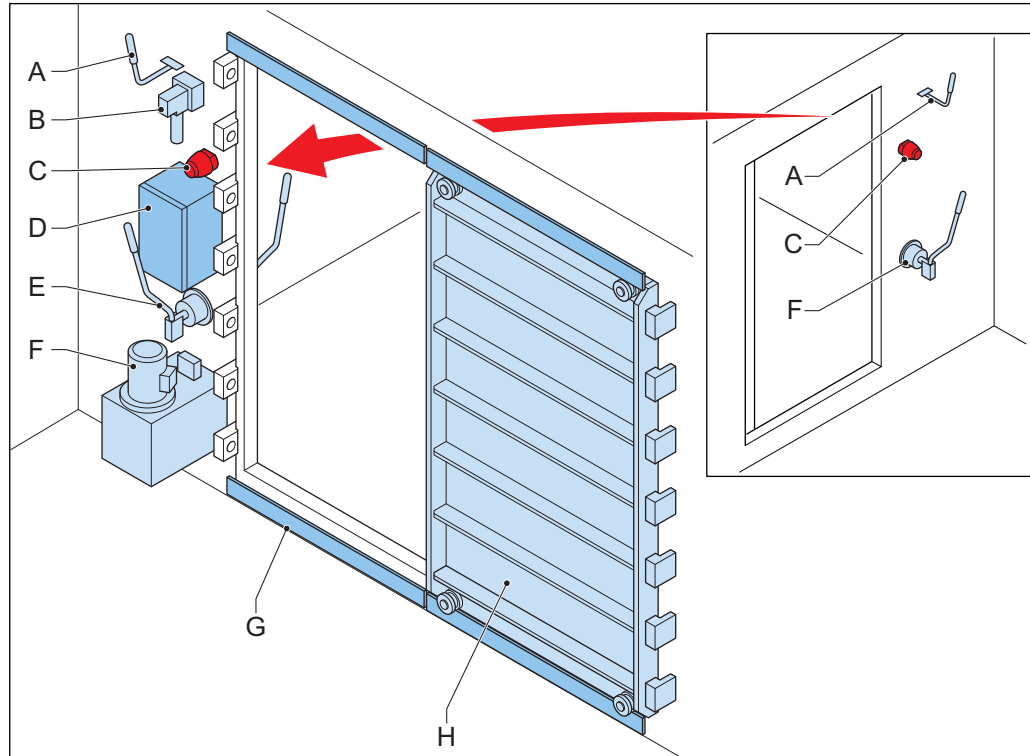

- A. Door handle (one on each side of the bulkhead)
- B. Direction control valve
- C. Sounder/flashlight (one on each side of the bulkhead)
- D. Electric control box
- E. Handle for the local handpump (one on each side of the bulkhead)
- F. Hydraulic unit
- G. Sliding rail
- H. Door plate

For specific details about the door installed on the vessel, refer to the GA drawings and the documentation enclosed.

#### 3.3.2 Overview of the Push button controls

The push button box is optional. Refer to the documentation enclosed to see if a push button box is installed.

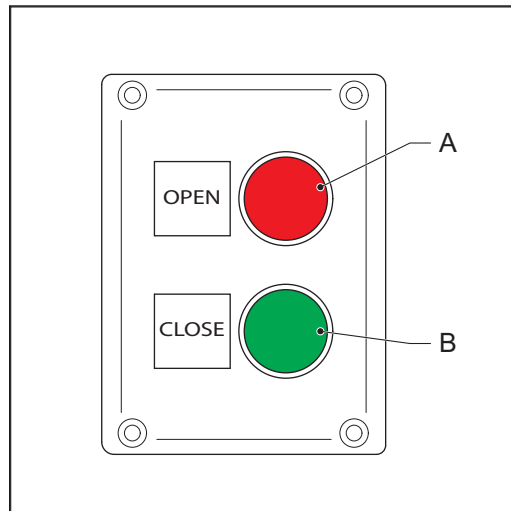

- A. Button **OPEN**
- B. Button **CLOSE**

### 3.3.3 Overview of the Emergency station

The emergency station is optional. Refer to the documentation enclosed to see if an emergency station is installed. The exact layout of an emergency station can differ per location and per vessel.

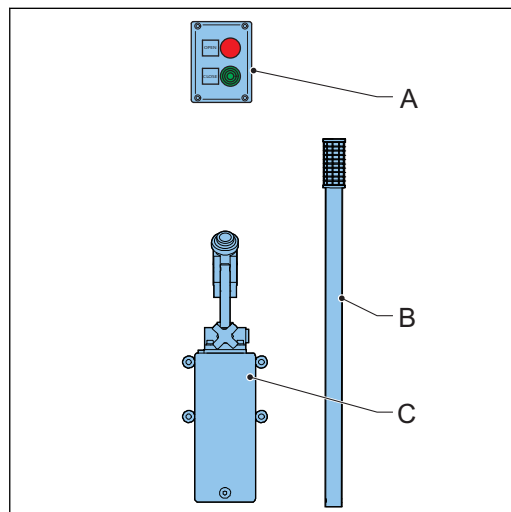

- A. Indication box
- B. Handle
- C. Handpump

### 3.3.4 Overview of the Indication box (emergency station)

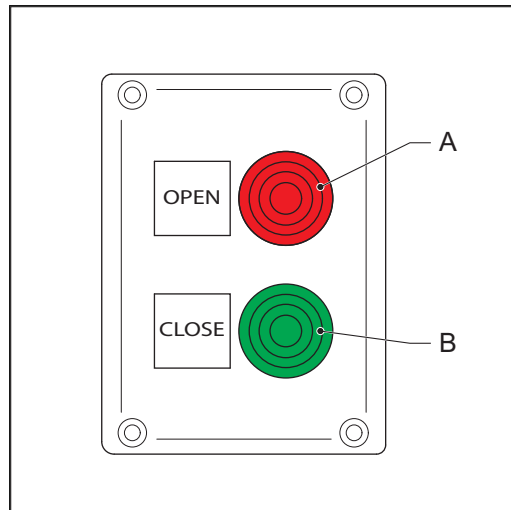

A. Indication **DOOR OPENED**

B. Indication **DOOR CLOSED**

### 3.3.5 Overview of the Handpump (emergency station)

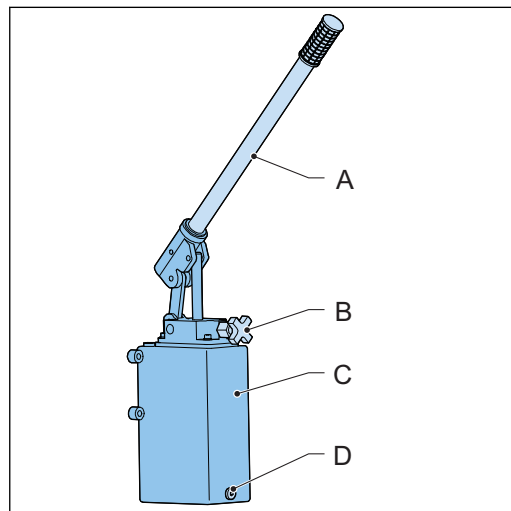

A. Handle

B. Manual valve

C. Buffer tank

D. Plug

### 3.3.6 Working principle

The electro-hydraulic door is operated by an electric powered hydraulic system and controlled by a PLC. The user can open and close the door with handles or pushbuttons (optional) that are located next to the door and at both sides of the bulkhead. The door handle or the pushbuttons operate the direction control valve which switches the door to open or to close.

If needed the door can also be operated manually by means of a handpump which is located next to the door and which can be operated from both sides of the bulkhead.

Optionally:

- The door can be closed from an emergency station above the freeboard deck.
- All doors can be closed from a wheelhouse panel (central close).

## 4 Installation

### 4.1 Delivery, insurance and acceptance

#### 4.1.1 Delivery

Depending on the scope of supply, the parts are packed and transported in the following ways:

##### **Door assembly**

The doorframe including the door is placed on a pallet and strapped with bands. Depending on the scope of supply, the electric components and the hydraulic components are pre-mounted on the doorframe, or they are delivered separately.

##### **Hydraulic components**

When the components are not pre-mounted on the doorframe, they are packed and sealed on labelled pallets and/or in boxes.

The label or packing list shows the contents of the box.

##### **Electric components**

When the components are not pre-mounted on the doorframe, they are packed and sealed in a labelled cardboard box. Inside this box, the components that belong to sub-systems (e.g. a wheelhouse panel) are packed per sub-system.

The contents of the boxes is shown on labels and on the packing list.

#### 4.1.2 Insurance

The responsibilities of transport and insurance are stated in the sales order confirmation and in the general conditions of sale of WINEL BV.

#### 4.1.3 Acceptance

During acceptance of the delivery, WINEL BV recommends to proceed as follows:

##### *Procedure*

1. WINEL BV recommends to have an authorized official of the transportation company present during this procedure.
2. Check if the packing and all the pallets and/or boxes are undamaged and if all parts are present.
  - a) Compare the labels with the WINEL BV packing list and the order confirmation.
  - b) If there is damage or if parts are missing, immediately report this to the sales department of WINEL BV.

### 4.2 Recommendations for handling and unpacking

##### **General**

- Use a fork lift or a hoist to transport the pallets or the boxes as close to the installation site as possible.

- Do not use hooks or other tools that may penetrate the packing and cause damage to the packed items.
- Only use lifting equipment with adequate capacity for the load.  
For the weights and dimensions of the delivery, refer to the GA drawings enclosed.
- Only unpack the parts in the cardboard boxes just before you install them. This prevents parts from being lost.
- Use a sharp knife to open the cardboard boxes but take care not to cause damage to the parts inside the boxes.

#### Door assembly (door frame with door and components)



**Danger:**

The door assembly is heavy.

Use correct and certified lifting materials.

Only authorized personnel is allowed to operate the lifting equipment.

Follow the appropriate safety procedures.

- Remove the band that holds the door assembly to the pallet.
- Make sure that the door itself is secured in the closed position. This prevents that the door moves during the lifting operation.
- Use the lifting eye on top of the door frame to attach the door to the lifting equipment.
- Use at least two steadying lines to guide the door assembly during the lifting operation.

## 4.3 Storage

### 4.3.1 Warehouse storage

- Store the parts in a safe, dry and dust free environment.  
This prevents unnecessary damage and wear of the parts.
- If the parts were unpacked from their transport packing, repack the parts using appropriate packing materials.
- Use the original WINEL BV WTSD pallet to store the door assembly.
- Do NOT stack pallets containing WTSDs on top of each other.

### 4.3.2 On-board storage

- Store the parts as close as possible to the future position.
- Make sure to place the door assembly at the correct side of the bulkhead.
- Make sure to protect the parts from damage caused by work in the vicinity of the parts.
- Re-pack or cover the door assembly and the other parts in order to prevent damage by grinding or welding nearby.

## 4.4 Welding

### 4.4.1 General welding recommendations



**Danger:**

Welding the door frame into or against the bulkhead must be done by certified and qualified welder and according to requirements of the shipyard.

WINEL BV cannot be held responsible if the welding recommendation and the advised welding procedures were not followed.

- WINEL BV can only make welding recommendations with respect to the WTSD, and not with respect to the construction of the vessel which the WTSD is placed into.

#### 4.4.2 Welding recommendations for the door frame



Caution:

**KEEP THE DOOR CLOSED DURING THE ENTIRE WELDING PROCEDURE.**

When the door is not closed during welding, the watertightness of the door cannot be guaranteed.

- For welding details, refer to the Welding and parts drawings enclosed.
- Make sure that the heat-dissipation into the door is as little as possible.
- Welding must be done carefully to prevent thermal stresses in the door.

#### 4.4.3 Welding recommendations for the sliding rail extension

- For welding details, refer to the Welding drawings enclosed.

##### Rail support

The upper and lower sliding rail extensions are equipped with rail supports. These supports (straight pieces of steel) must be adapted to the desired mounting position on the deck or on the bulkhead. This mounting position must be determined by the installation surveying personnel of the shipyard. The adapted support must be welded on the mounting position.



**Note:** The low sill doors only have rail supports at the upper sliding rail.

## 4.5 Hydraulics

### 4.5.1 Prepare the hydraulics for installation



Danger:

Always switch off all hydraulic power and deplete the pressure from the entire system before you do any installation, removal or maintenance work.

##### Procedure

1. Remove the temporary sealing, plugs etc. only just before you install the parts.  
The hydraulic unit and the handpump delivered by WINEL BV are factory flushed and sealed.
2. Make sure that piping is clean and free from scale, rust, flux etc.

### 4.5.2 Connect the hydraulics

Refer to the hydraulic diagram enclosed.



### 4.5.3 Flush the piping of the hydraulics



**Caution:**

The piping between the emergency station, the accumulator and the WTSD must be flushed before operation.

Only a one-door system can be flushed in one operation. Systems that contain multiple doors, must be divided into sections or loops which are each flushed in turn.

Required standards are:

- NAS 1638: 7-8
- ISO 4406: 16/13

**Procedure**

1. Bypass the components that are supplied in clean condition and that may restrict the flow or that may be damaged by the flushing procedure.  
These components have been flushed on assembly. They include reservoirs, pump-motors, dead-end components (e.g. cylinders) servo-valves, flow regulators and other valves containing small orifices.
2. Flush each section or loop according to the applicable flushing procedures.
3. Remove the bypasses and re-connect the hydraulic system.  
Refer to the hydraulic diagram enclosed.

### 4.5.4 Fill the hydraulic unit with hydraulic fluid

**Preparation**

**Procedure**

1. Make sure to use the correct hydraulic fluid. Especially the correct viscosity is important.  
Refer to the hydraulic diagram enclosed.
2. Make sure that the piping between the emergency station (if present) and the hydraulic unit is clean, filled and air-bleeded.
3. Clean the filler screw and the filler cap of the hydraulic tank.

**Fill the hydraulic tank**

**Procedure**

1. Open the tank (B) by removing the filler cap (A).
2. Check the tank for dirt or water, and clean the tank if necessary.
3. Fill the tank with hydraulic fluid. The fluid must at least reach the dipstick.
4. Close the tank.
5. Switch on the power of the hydraulic unit.  
This switch is located in the electric control box.

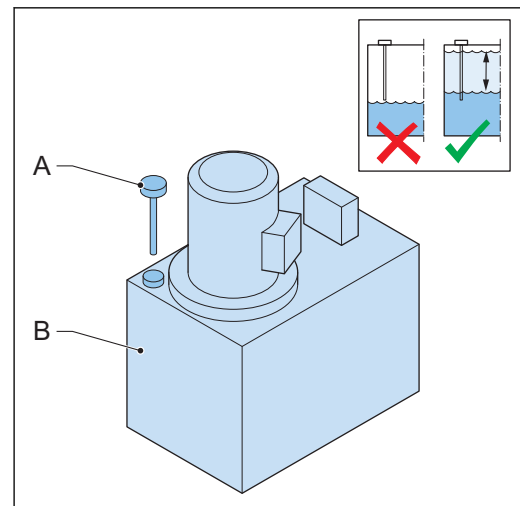

### Fill the handpump of emergency station (optional)

The emergency station is optional. Refer to the documentation enclosed to see if an emergency station is installed.

#### Procedure

1. Open the manual valve of the handpump.
2. Open and close the door several times.  
The system automatically fills the tank of the handpump.
3. Check if the tank of the handpump is completely full.
4. If the tank of the handpump is full, close the manual valve of the handpump.

### Check the level of the hydraulic fluid

#### Procedure

1. Open the tank.
2. Check if the fluid level at least reaches the dipstick.
3. If the fluid level is below the dipstick, refill the tank until the level reaches the dipstick, or higher.

## 4.5.5 Air-bleed the hydraulics

Normally the system dissolves air by closing and opening of the doors. But after a complete refill of the hydraulic fluid, or when parts have been removed and re-connected, air-bleed the system as follows:

#### Procedure

1. Circulate the hydraulic fluid through the system.
  - a) Use the handpump.
  - b) Open and close the door by operating the door handle.
2. Open the couplings and (if present) other bleeding plugs one by one and fasten them when hydraulic fluid starts flowing from the opening. Start at the lowest point in the hydraulic system.
3. Check the level of the hydraulic fluid and fill up the fluid level if necessary.

## 4.6 Electrics

### 4.6.1 General remarks about the electrical connection



#### Caution:

Always switch off all electrical power before you do any installation, removal or maintenance work.

- Refer to the overview diagram enclosed for cable information (wires/diameters).

### 4.6.2 Connect the control box and the indication panel

#### Procedure

Connect the external electrical connections to the terminal strip inside the control box or inside the indication panel.

Refer to the connection diagrams enclosed.

#### **4.6.3 Connection of the proximity switches**

The proximity switches on electric and electro-hydraulic WTSD are pre-mounted and connected to the terminal strip.

No additional connection work is required.

#### **4.6.4 Connection of the local sounder and flashlight**

The local sounder/flashlight on electric and electro-hydraulic WTSDs are pre-mounted and connected to the terminal strip.

No additional connection work is required.

#### **4.6.5 Connect the push buttons**

The push buttons are optional. Refer to the documentation enclosed to see if push buttons are installed.

The push buttons are installed in push button boxes on both sides of the bulkhead.

These boxes:

- Must be mounted on a mounting plate that must be welded on the bulkhead at a height of at least 1.6 m from the floor
- Must both be reachable at the same time by one person when the door is open.

Procedure

1. Mount the push button box to the mounting plate.
2. Connect the push buttons to the terminal strip inside the control box.  
Refer to the connection diagrams enclosed.

#### **4.6.6 Connection of the indication box (emergency station)**

The emergency station is optional. Refer to the documentation enclosed to see in an emergency station is installed

Procedure

1. Mount the indication box at the desired location on the emergency station.
2. Connect the indication box to the terminal strip inside the control box.  
Refer to the connection diagrams enclosed.

## 5 Commissioning

### 5.1 General commissioning recommendations

When the installation of the WTSD is completed, the WTSD must be commissioned. This involves the following procedures that must get full attention:

- Visual inspection;
- Checks before operation;
- Operational tests.

### 5.2 Visual inspection

Procedure

1. Examine the WTSD for damage, dirt and leaks of hydraulic fluid.
2. If necessary, replace damaged parts.
3. If necessary, repair any leaks or damage and remove dirt.

### 5.3 Checks before operation

#### 5.3.1 Checks of the door and the frame

Procedure

1. Examine the door seal and the seal face of the door for damage and dirt.
2. If necessary, repair any damage and clean the items.
3. If the door seal is damaged, replace the door seal.
4. Lubricate the door seal with acid free Vaseline.

#### 5.3.2 Check of the valve settings

Procedure

Make sure that the following valves or plugs are closed:

- a) the air vent plugs / valves;
- b) the manual valves on the handpumps of the emergency stations.

#### 5.3.3 Check of the hydraulic unit

Procedure

1. Check if the level of the hydraulic fluid at least reaches the dipstick.
2. If necessary, fill up the tank to the required level.

## 5.4 Operational test

### 5.4.1 Normal operation

#### Local manual operation



#### Caution:

Make sure that there are no obstacles that prevent the door from closing or opening.

#### Procedure

1. Switch on the main power to the hydraulic unit.  
This switch is located in the electric control box.
2. Operate the door handle or the optional local push buttons, and check if:
  - a) The door opens and closes, depending on the position of the door handle or the selected button.
  - b) The local sounder/flashlight makes a sound and flashes when the door opens or closes.
  - c) The opening time and the closing time of the door is between 20 and 40 seconds (for doors with a clear opening width of max. 1200 mm)
  - d) (optional) The indicator lights of the emergency station or other remote control positions change color depending on the door position.
    - Door closed: green light
    - Door open: red light
    - Door in intermediate position (between open and closed): red light flashes

#### Remote operation from the wheelhouse panel

The wheelhouse panel is optional. Refer to the documentation enclosed to see if a wheelhouse panel is installed.



#### Caution:

Make sure that there are no obstacles that prevent the door from closing.

#### Procedure

1. On the wheelhouse panel, set the switch **MASTERMODE** to **CENTRAL CLOSE**, and check if:
  - The indicator **CENTRAL CLOSE** lights up.
  - Within 5-10 second all open doors start closing.
  - The red indicator light of each door flashes until the door is closed.
  - When the door is closed, the green indicator lights up.
2. On the wheelhouse panel, set the switch **MASTERMODE** to **LOCAL CONTROL**.

### 5.4.2 Emergency operation

#### Local manual operation

#### Procedure

1. Switch off the main power to the hydraulic unit.  
This switch is located in the electric control box.

2. Operate the door handle and the local handpump, and check if:
  - a) The door opens when the door handle is held towards the open-position.
  - b) The door closes when only the handpump is operated.
  - c) The door closes within 90 seconds (for doors with a clear opening width of max. 1200 mm)
  - d) (optional) The indicator lights of the emergency station or other remote control positions change color depending on the door position.
    - Door closed: green light
    - Door open: red light
    - Door in intermediate position (between open and closed): red light flashes

### **Emergency station**

The emergency station is optional. Refer to the documentation enclosed to see if an emergency station is installed.

#### **Procedure**

1. Go to the emergency station above the freeboard deck.
2. Operate the handpump or the generator, and check if:
  - a) The door closes within 90 seconds (for doors with a clear opening width of max. 1200 mm)
  - b) The indicator lights of the emergency station change color depended on the door position.
    - Door closed: green light
    - Door open: red light
    - Door in intermediate position (between open and closed): red light flashes
  - c) The local sounder/flashlight makes a sound and flashes when the door closes (only when electrical power is available).

## 6 Operation

### 6.1 Normal operation

#### 6.1.1 Pass a door

##### Open the door

###### Procedure

1. Hold the door handle in the opening direction until the door is fully opened.  
Optional: use the button **Open**.  
The door moves and the sounder and flashlight are active until the door is fully opened.
2. If you release the door handle or the button, the door stops.  
If the door is controlled from the wheelhouse, the door closes after 5-10 seconds. The sounder and the flashlight will stay active until the door is fully closed.

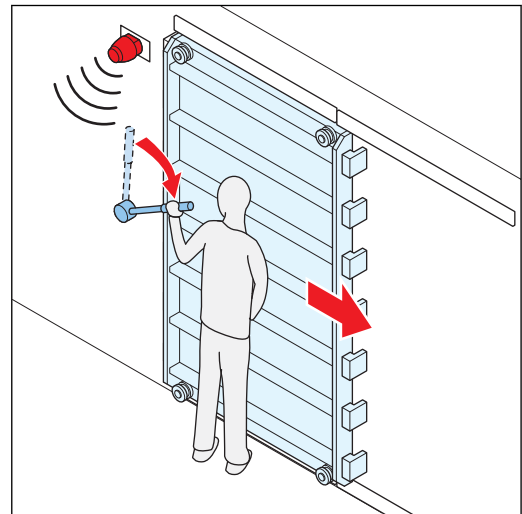

##### Step through the door opening

###### Procedure

1. Use both hands to hold both door handles in order to keep the door open.  
Optional: use the buttons **Open**.
2. Step through the door opening.

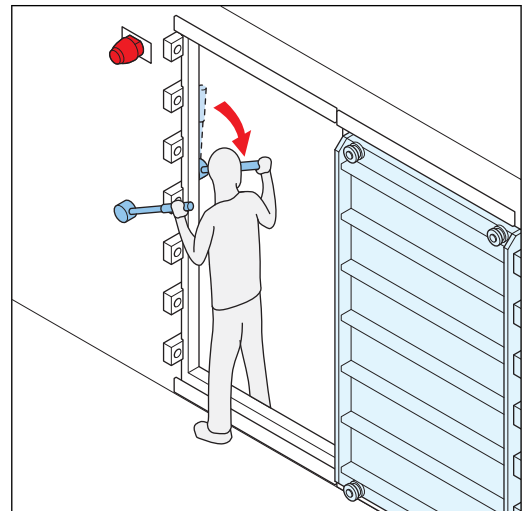

### Close the door

#### Procedure

1. Stand clear of the door.
2. Hold the door handle in the closing direction until the door is fully closed.

Optional: use the button **Close**.

The door moves and the sounder and flashlight are active until the door is fully closed.

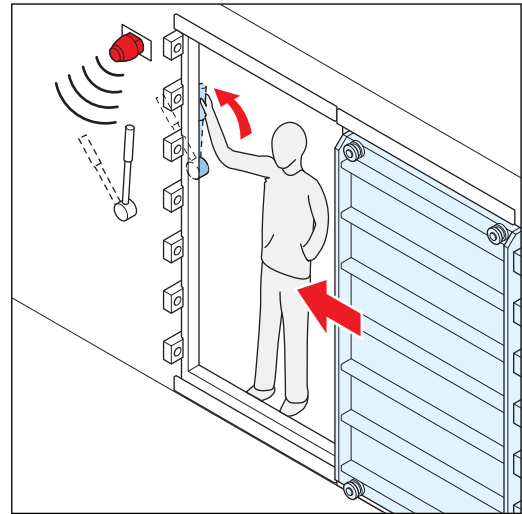

## 6.1.2 Remote operation from the wheelhouse panel

The wheelhouse panel is optional. Refer to the documentation enclosed to see if a wheelhouse panel is installed.

### Set all doors to central control



#### Caution:

Make sure that there are no obstacles that prevent the door from closing.

#### Procedure

1. On the wheelhouse panel, set the switch **MASTERMODE** to **CENTRAL CLOSE**.
  - The indicator **CENTRAL CLOSE** lights up.
  - Within 5-10 second all open doors start closing.
  - The red indicator light of each door flashes until the door is closed.
  - When the door is closed, the green indicator light lights up.
2. Check the indicator lights to see if all doors are closed.

All doors are now closed, and they will remain closed. When a person wants to pass a door, he/she has to use the local controls. As soon as the local controls are released, the door automatically closes again.

### Open all doors

Opening the doors is NOT possible from the wheelhouse panel.

### Set all doors to local control

#### Procedure

1. On the wheelhouse panel, set the switch **MASTERMODE** to **LOCAL CONTROL**.
2. Check if the indicator **CENTRAL CLOSE** is off.  
All doors can now be fully controlled locally. If a person at the door releases the local controls, the door will stay in its current position.



## 6.2 Emergency operation

### 6.2.1 Local operation

#### General

These procedures must be followed when the door cannot be operated in the normal way (e.g. during a power failure).

#### Open the door

##### Procedure

1. Put the handle (B) into the handpump (C).
2. Hold the door handle (A) in the opening direction and use the handle of the handpump to operate the handpump until the door is fully opened.

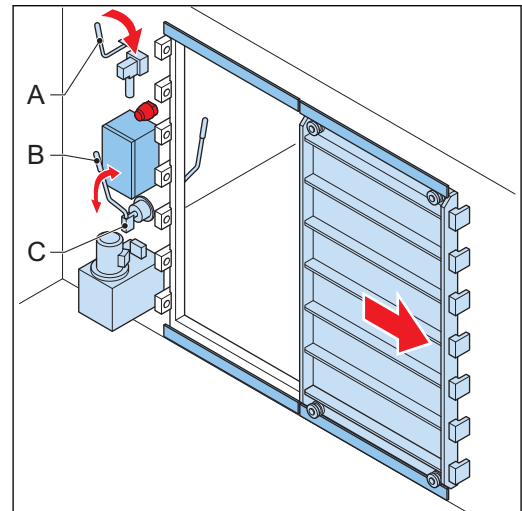

#### Close the door

##### Procedure

1. Use the handle (A) of the handpump (B) to operate the handpump until the door is fully closed.
2. Remove the handle from the handpump.
3. Put the handle back in its storage position.

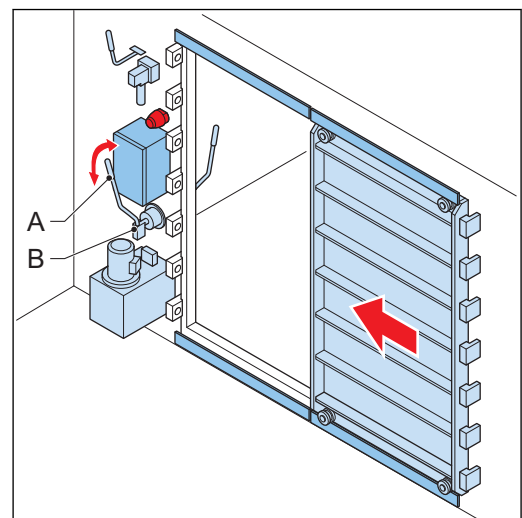

### 6.2.2 Use the emergency station to close the door

The optional emergency station can only be used to close the door.

This procedure must be followed when the door cannot be closed in a normal way: locally via the handpump or remotely via the wheelhouse panel.

Procedure

1. Make sure that the valve (B) of the handpump is closed.  
This valve must be closed at all times except when filling the tank of the handpump.
2. Put the handle (A) into the handpump.
3. Operate the handpump until the door is fully closed.  
The indicator lights show the position of the door.
4. Remove the handle from the handpump.
5. Put the handle back in its storage position.

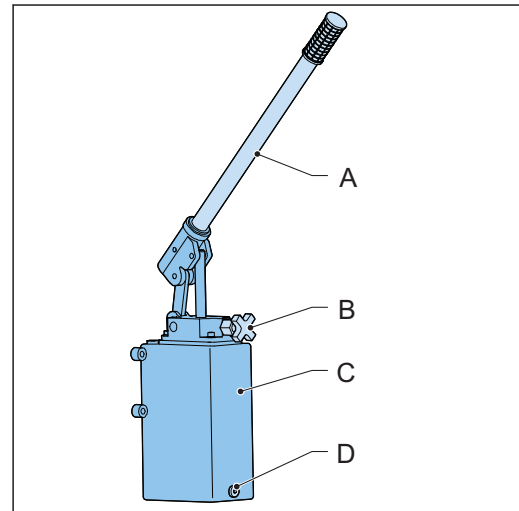

## 7 Maintenance

### 7.1 Maintenance schedule

#### Inspection intervals

##### Daily and (on vessels) before departure:

- Check the free passage of the door and remove obstacles that prevent the door from closing.
- Check for external leaks.
- Check for dirt or damage.
- Check for unusual noises from pumps, motors, couplings, mountings etc.
- Check for proper functioning of instruments.

##### Weekly:

- Check if the level of the hydraulic fluid at least reaches the dipstick. Fill up if necessary.
- Check the door seal and the sealing surface of the door for damage.
- Check the wedges and blocking cones.  
Lubricate them if necessary.
- Clean the rails and the sill (if applicable).

##### Monthly:

- Check the pressure settings of the hydraulic fluid.
- Check the operation of the complete system, including the visible and audible alarms.

##### Every two months:

- Check the settings and signalling devices.

#### Service intervals

##### Filters for hydraulic fluid:

- First replacement of the filter: after approximately 3 months.
- Next replacement: every 6 months.

##### Hydraulic fluid:

- Take a fluid sample every year.  
Fluid samples can be analysed by WINEL BV.
- Depending on the result of the analyses, replace the hydraulic fluid. Refer to the Viscosity-temperature diagram enclosed.

### 7.2 Maintenance tasks

#### 7.2.1 General recommendations for maintenance

Regular inspections and maintenance helps to keep the product in optimal condition. Be constantly alert for:

- External leaks
- Dirt
- Damage, especially to hoses and pipes

- Unusual noises from pumps, motors, couplings, mountings etc.
- Proper operation of instruments

**Cylinder rods**

Regularly open and close the door. This makes the hydraulic cylinder retract and extend. By retracting the cylinder, the cylinder rod will keep a thin film of hydraulic fluid which lubricates the cylinder rod.

The intervals depend on the circumstances. The interval can vary from daily (coastal areas and marine applications) to weekly.

**Grease and corrosion inhibitors**



**Caution:**

Do NOT lubricate the bearing of the wheels. The wheels are equipped with self-lubricating bushes. If lubrication is nevertheless necessary, use PH neutral grease.



**Note:**

Some types of corrosion inhibitors can cause damage to seals and/or can react with hydraulic fluid.

**7.2.2 Visually inspect hydraulic fluid**

The condition of hydraulic fluid over time depends on a number of operating parameters such as: temperature, pressure, air humidity etc. A visual inspection can help to quickly see the condition of the fluid and of the hydraulic system.

*Procedure*

1. Take a sample of the hydraulic fluid from the hydraulic system.
2. Examine the sample to see if it corresponds with a condition from the table.

Appearance	Contaminants	Possible cause of the contamination
Dark in color	Product of oxidation	<ul style="list-style-type: none"> <li>• Overheating</li> <li>• Insufficient fluid changes</li> <li>• Possible ingress of other fluid</li> </ul>
Milky	Water of foam	<ul style="list-style-type: none"> <li>• Ingress of water or air</li> </ul>
Water separation	Water	<ul style="list-style-type: none"> <li>• Ingress of water (e.g. cooling water)</li> </ul>
Air bubbles	Air	<ul style="list-style-type: none"> <li>• Ingress of air (e.g. due to low fluid level or leaky suction)</li> </ul>
Floating or sunken contaminants	Solid contaminants	<ul style="list-style-type: none"> <li>• Wear</li> <li>• Dirt</li> <li>• Ageing</li> </ul>
Smell of burnt oil	Product of aging	<ul style="list-style-type: none"> <li>• Overheating</li> </ul>

3. If you suspect that the hydraulic fluid is contaminated, WINEL BV advises to have the fluid analysed by a specialized company.

### 7.2.3 Replace a filter for hydraulic fluid

Contaminated hydraulic fluid is a major cause of malfunctions of hydraulic systems. Filters help to keep the hydraulic fluid clean. Therefore the filters themselves must be replaced at regular intervals. To replace a filter:

Procedure

1. Switch off the main power to the hydraulic unit.
2. Remove the pressure from the entire system.
3. Remove the old filter.
4. Install the new filter. For the correct filter type and part number, refer to the documentation enclosed.
5. Switch on the main power to the hydraulic unit.

### 7.2.4 Apply new paint

All corrodible parts of the WTSD are covered by a protective paint. Only repaint the part if necessary. Use the original colors.



**Note:**

Paint at the wrong location can cause system failure or it can obstruct an easy removal of system parts.

If you apply new paint:

Procedure

1. Do not paint non-painted parts such as: proximity switches, cylinder rods, control boxes and indication boxes.
2. Cover parts that do not need new paint.

### 7.2.5 Clean and grease the door seal and the seal contact face of the door

Procedure

1. Clean the door seal and the seal contact face of the door. Use a dry cloth.
2. Apply a little acid free Vaseline to the door seal.